

# IQAN-MD4

## Instruction book

Publ no MSG17-8408-IB/UK  
Edition 2022-11-04

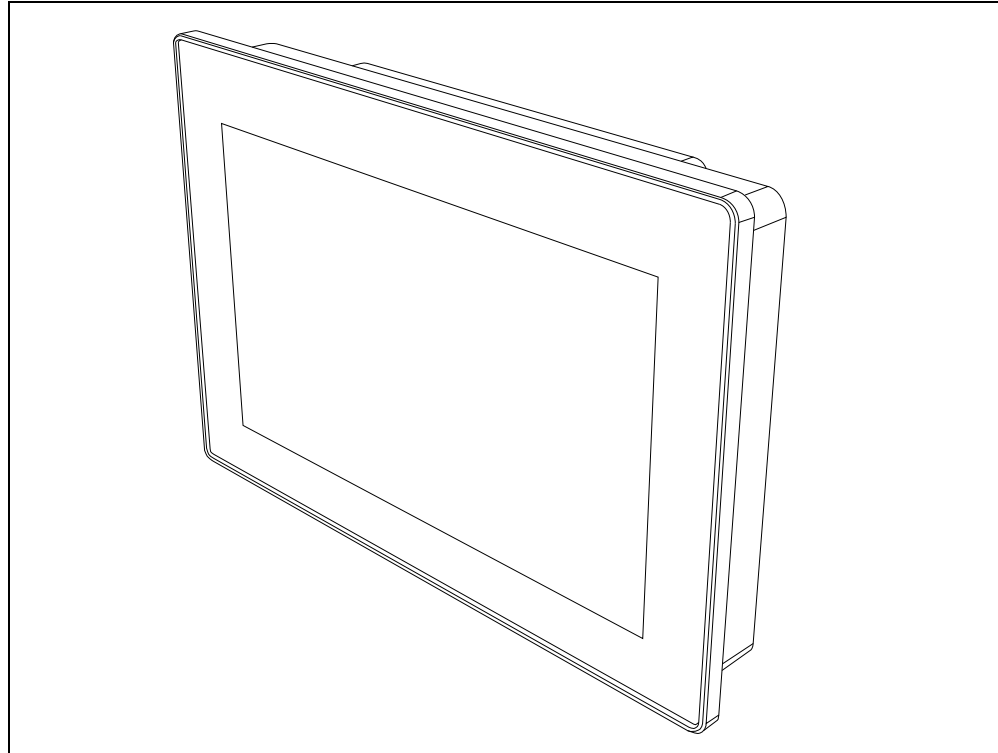

## Publication history

The following table provides an overview of the changes made to this document over the course of its publication history.

Revision / date	Description of change
Rev. 001 / 2015-02-26	Added MD4-10 specs to appendices
Rev. 002 / 2015-12-03	Added MD4-5 and MD4-7 bracket mounting pattern and P/Ns
Rev. 003 / 2016-10-26	Added recommendation about choice of diagnostics bus
Rev. 004 / 2017-22-02	Clarification of CAN port and Ethernet port quantities by variant
Rev. 005 / 2018-09-13	Added copy of DoC to Markings/Approvals
Rev. 006 / 2019-09-20	Added MD4-5 M19 Appendix information
Rev. 007 / 2019-10-16	Problem with missing images in previous version corrected
Rev. 008 / 2020-01-10	Offer of sale removed
Rev. 009 / 2020-08-11	Markings / Approvals added to appendix A
Rev. 010 / 2021-04-26	Removed touch depends on variant for MD4-5-M19
Rev. 011 / 2021-05-19	Declaration of conformity updated
Rev. 012 / 2022-11-04	UKCA Declaration of conformity added

### Copyright 2018 © Parker-Hannifin Corporation. All rights reserved.

No part of this work may be copied, reproduced, replaced, distributed, published, displayed, modified, or transferred in any form or by any means except with the prior permission of Parker-Hannifin Corporation.

### Warning

FAILURE OR IMPROPER SELECTION OR IMPROPER USE OF THE PRODUCTS AND/OR SYSTEMS DESCRIBED HEREIN OR RELATED ITEMS CAN CAUSE DEATH, PERSONAL INJURY AND PROPERTY DAMAGE.

- This document and other information from Parker Hannifin Corporation, its subsidiaries and authorized distributors provide product and/or system options for further investigation by users having technical expertise.
- The user, through its own analysis and testing, is solely responsible for making the final selection of the system and components and assuring that all performance, endurance, maintenance, safety and warning requirements of the application are met. The user must analyze all aspects of the application, follow applicable industry standards, and follow the information concerning the product in the current product catalog and in any other materials provided from Parker or its subsidiaries or authorized distributors.
- To the extent that Parker or its subsidiaries or authorized distributors provide component or system options based upon data or specifications provided by the user, the user is responsible for determining that such data and specifications are suitable and sufficient for all applications and reasonably foreseeable uses of the components or systems.

## Contents

	Publication history	ii
<b>1</b>	<b>Introduction</b>	<b>1</b>
	Warnings	1
	Overview of relevant documentation	2
<b>2</b>	<b>Precautions</b>	<b>3</b>
	Read This	3
	Design of control system	3
	Start-up, maintenance, and diagnostics	4
<b>3</b>	<b>Product description</b>	<b>5</b>
	IQAN-MD4	5
	System overview	5
	I/O	6
	Voltage inputs	6
	Digital inputs	6
	Communication	7
	CAN related functions	7
	Ethernet	7
	HMI (human machine interface)	7
	Display	7
	Markings/Approvals	9
<b>4</b>	<b>Safety</b>	<b>10</b>
	Internal diagnostics	10
	CAN-bus interruption	10
	Current check	10
	Emergency stop	10
<b>5</b>	<b>Mounting</b>	<b>11</b>
	Mounting the module	11
	Dashboard or panel assembly	11
	Ball or tilt/swivel mount	11
	Mounting considerations	12
<b>6</b>	<b>Installation</b>	<b>13</b>
	Connector C1 and C2	13
	Connector C1 pin assignments	14
	Connector C2 pin assignments	14
	Connector C3 and C4	15
	Supply voltage	16
	Emergency stop	16
	Connecting of Supply Voltage	16
	Polarity reversal	16
	Addressing	17
	IQAN-MD4 use of an ID-Tag	17
	Identification of an IQAN-MD4 by address	17
	Diagnostic interfaces	18
	CAN diagnostics connection	18
	Ethernet diagnostics communication	19
	Video input	19
	Analog Cameras	21

Reference voltage, VREF	22
Voltage inputs	23
Connecting sensors to the voltage inputs	23
Connecting a 2-wire temperature sensor to voltage in	24
Connecting switches to the voltage inputs using VREF	24
Connecting switches to the voltage inputs using +BAT	25
Directional pulse count input	26
Connecting a directional pulse count channel (DPCNT)	26
Low-side digital outputs	27
<b>7 Start-up</b>	<b>28</b>
Start-up procedures	28
Starting the control system	28
Prepare for system start	28
Start the system	28
<b>Appendix A</b>	<b>29</b>
IQAN-MD4 Technical Overview	29
<b>Appendix B</b>	<b>33</b>
Error messages and actions	33
Failure Modes	33
Failure modes for CAN interface	33
Failure modes for VREF	34
Failure modes for VIN	34
Failure modes for DIN	34
<b>Appendix C</b>	<b>35</b>
Dimensioning of the IQAN-MD4-7	35
Dimensioning of the IQAN-MD4-5	36
Dimensioning of the IQAN-MD4-10	37
Dimensioning of the IQAN-MD4 bracket	38

# 1 Introduction

These instructions are to be used as a reference tool for the vehicle manufacturer's design, production, and service personnel.

The user of these instructions should have basic knowledge in the handling of electronic equipment.

## Warnings

Sections marked with a symbol in the left margin, must be read and understood by everyone using the system, carrying out service work, or making changes to hardware and software.

The different symbols used in this manual are defined below.



### **WARNING**

Sections labeled *WARNING* with a caution symbol in the left margin, indicate that a hazardous situation exists. We use warnings, marked with the warning symbol, in two ways.

- As a strong recommendation about work practices when using the product in the machine (e.g. routines when updating an application). This use is common to the term 'hazardous situation', that a person is exposed to a hazard.
- As a way of pointing out important information for the machine designer that in some way relates to safety. This includes the design of the physical machine, and also the application program being developed for the control system.

Not all document sections that contain information about safety are marked with a warning symbol (there would be warnings everywhere). Failure to comply with the recommendations can cause unintentional, and unexpected behavior of the control system. This can potentially cause death, serious injury or property damage.



### **NOTICE**

Sections labeled *NOTICE* with a notice symbol in the left margin, indicate there is important information about the product. Ignoring this could result in less than optimal performance, or damage to the product.

Contact the manufacturer if there is anything you are not sure about or if you have any questions regarding the product and its handling or maintenance.

The term "manufacturer" refers to Parker Hannifin Corporation.

## Overview of relevant documentation

The following publications are relevant for users of this product.

The main documentation contains information that is not found elsewhere.

The additional documentation contains product information in a compact format, for details on the information found in those documents, consult this manual.

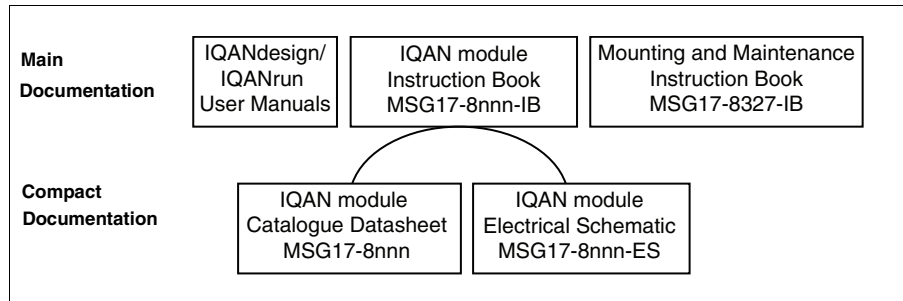

The IQAN module documentation system.

## 2 Precautions

Work on the hydraulics control electronics may only be carried out by trained personnel who are well-acquainted with the control system, the machine and its safety regulations.



### **WARNING**

Make sure that you have sufficient knowledge before designing, modifying or servicing the control system.

Read the relevant sections of this document before conducting any work on the control system.



### **WARNING**

This product is not field repairable.



### **NOTICE**

As much as possible of the welding work on the chassis should be done before the installation of the system. If welding has to be done afterwards, the electrical connections on the system must be disconnected from other equipment. The negative cable must always be disconnected from the battery before disconnecting the positive cable. The ground wire of the welder shall be positioned as close as possible to the place of the welding. The cables on the welding unit shall never be placed near the electrical wires of the control system.

## Read This

### **Design of control system**



### **WARNING**

Risk of injury may be introduced by design of control system!

This product is designed to control hydraulic outputs. The control application must be designed using basic safety principles so that unintentional movement is avoided.

The machine must be equipped with an emergency stop that stops all movement. Please refer to section "Supply voltage".

### **Before you start**

Read this document.

Read the IQANdesign software user manual section on 'application safety'.

## **Start-up, maintenance, and diagnostics**

For all personnel carrying out installation, commissioning, maintenance or troubleshooting.



### **WARNING**

Work on the hydraulics control electronics may only be carried out by trained personnel who are well-acquainted with the control system, the machine and its safety regulations.

### **Before you start,**

Read section "Start-up".

### **Additional information for service**

Mounting and maintenance instruction book.

### **Additional information for diagnosing the system**

Read section "System diagnostics", and see "Appendix B", in this document.

Use the IQANrun software user manual as a reference.



## 3 Product description

### IQAN-MD4

The IQAN-MD4 is a family of combined display and bus master modules capable of running applications created by IQANdesign software. Built on a 32-bit platform the units have large computational power and is capable of controlling large applications.

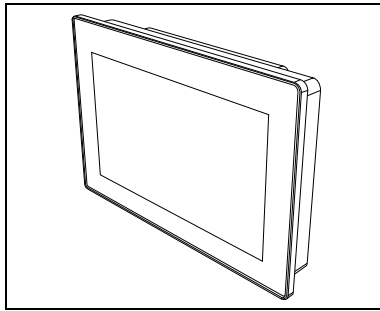

The IQAN-MD4 module.

### System overview

The master module, IQAN-MD4, is the central unit in the system, or in the case of a multi-master system, one of the central units. IQAN-MD4 has four CAN buses and two ethernet ports. The CAN buses support ICP and are able to control IQAN expansion units. SAE J1939 and Generic CAN protocols are also supported on the CAN buses and gives the possibility to interface to 3rd party units.

A touch screen in combination with a graphical display makes system feedback with user interaction possible. The display in the module has very high optical performance across a wide operating temperature range and over a wide range of ambient light. IQAN-MD4 has voltage and digital inputs that are designed to be flexibly configured using IQANdesign software. The unit also has four low side digital outputs. All I/O are EMI filtered and protected against short circuit to -BAT and +BAT.

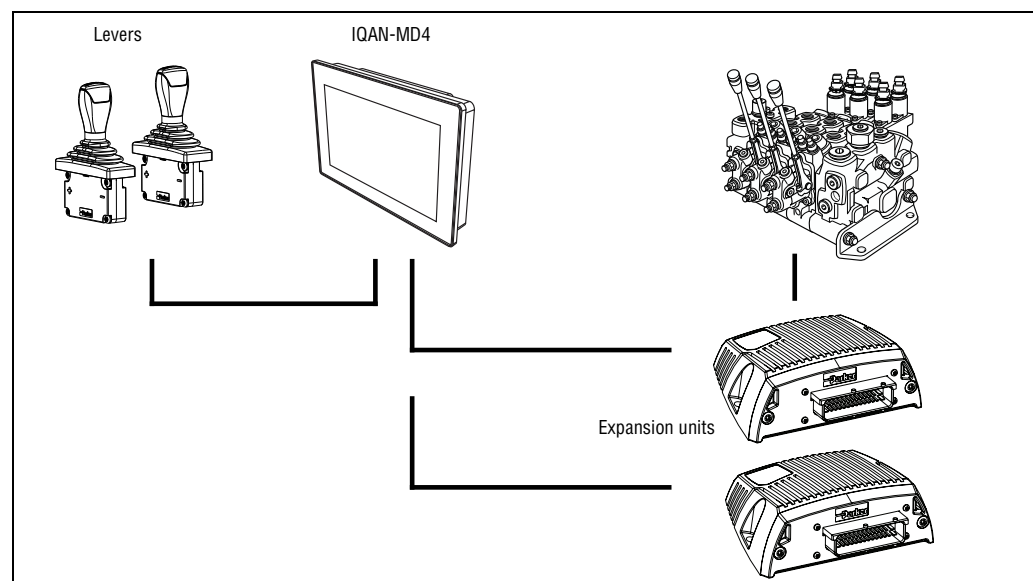

A typical IQAN-MD4 System

## I/O

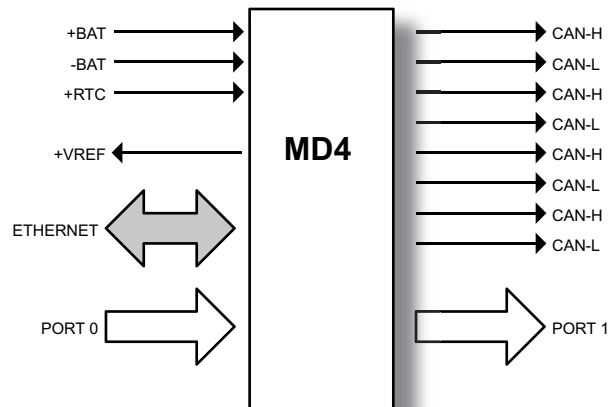

### Voltage inputs

The IQAN-MD4 module has two (2) voltage inputs VIN-A and VIN-B for connection of 0-5 Vdc signals. These inputs can be configured as digital inputs for reading switches. Voltage inputs and digital inputs share positions, see below.

---

(2) Voltage inputs VIN-A and VIN-B

or

(2) Digital inputs DIN-I and DIN-J

---

### Digital inputs

The IQAN-MD4 module has eight (8) digital inputs DIN-A thru DIN-H. DIN-A thru DIN-D are multi purpose and can be configured as low-side *on/off outputs*. DIN-G and DIN-H are multi purpose and can be configured as a *directional pulse count input*. see below.

---

(8) Digital inputs DIN-A thru DIN-H

or

(4) Digital inputs DIN-E thru DIN-H, (4) Digital outputs DOUT-A thru DOUT-D

or

(6) Digital inputs DIN-A thru DIN-F, (1) Directional pulse count input DPCNT

---

## Communication

The communication interfaces are used for uploading/downloading applications, connecting to expansion modules, connecting to cameras or diagnostics.

### CAN related functions

The IQAN-MD4 uses a CAN-bus (CAN = Controller Area Network) to communicate with IQAN expansion modules and other systems. The CAN-bus is a robust communication protocol that is widely used and well proven within the automotive industry.

The non-touch version MD4-5-T0E1 has two (2) CAN buses, CAN-A and CAN-B. All other versions have four (4) CAN buses, CAN-A to CAN-D. The CAN buses may be configured in IQANdesign to be used for IQAN expansion modules, IQAN diagnostic and multi-master traffic, SAE J1939 modules (e.g. for engine and transmission), or as Generic bus for user defined CAN protocol (suitable also for CANopen).

### IQAN diagnostics bus

The IQAN diagnostics bus is used for communication between master units in a multi-master system, and also as a gateway to an IQAN-G11 or to a connected PC (requires compatible USB to CAN adapter).

In the IQAN-MD4, the CAN channels are paired in groups of 2. There is CAN-A and CAN-B, where the CAN controllers are in the main processor, compared to CAN-C and CAN-D, that are controlled by the co-processor.



### NOTICE

On the IQAN-MD4, the buses CAN-C and CAN-D have a lower throughput rate for bursts of CAN traffic.

It is recommended to use CAN port A or B for diagnostics on the MD4 module, especially in multi-master systems.

### Ethernet

The MD4 has up to two Ethernet communication ports depending on configuration, Port A (C3) and Port B (C4).

Port A is used for uploading/downloading applications and diagnostics and is designated for computer communication. see *Ethernet diagnostics communication* for more information.

Port B is used for in-vehicle network over Ethernet, for example communicating with camera or other masters. see *Video input* for more information on how to use cameras.

## HMI (human machine interface)

### Display

#### Touch function

The IQAN-MD4 display has a capacitive touch screen (PCAP touch screen) enabling the user to control the display with the use of fingers, passive stylus, thin gloves or thicker gloves with conductive material in the finger tips. The touch sensor is protected from wear behind a glass surface.

#### **Landscape and Portrait mode, Polarization**

The MD4 software supports both landscape (default) and portrait mode orientation.

The MD4-7 (7") screen has polarizers, and the display component is defined as landscape mode display. In an application where the MD4-7 is used in portrait mode, and when wearing polarized sunglasses, the effect is that the screen can be unreadable due to the conflicting polarizations. This is easily solved by applying a film to the display. One type of film that is proven to work is NuShield DayVue anti-reflective overlay film.

The MD4-5 and MD4-10 screens do not have polarizers.

#### **Scratch resistance**

In order to maximize the life cycle of the optical performance of the display, the glass surface does not have any anti-reflection treatment. Such surface treatments have a tendency to mechanically wear down over time and would give a worn out appearance of the display and a reduced optical performance.

#### **Maintenance**

Reasonable care should be taken to maintain the glass.

The display can be cleaned with an LCD cleaning solution found in many stores. Use a lightly dampened lint-free, non-abrasive cloth when cleaning the display.



#### **NOTICE**

To avoid scratches, do not wipe or clean a dry display.

#### **Water**

IQAN-MD4 is a hardened module suitable for both in-cab and outdoor use.

The display will not be damaged by water, but the touch sensor has been tuned to reduce the risk of unintentional activation of buttons from water drops. The touch interface can have limited functionality if an excessive amount of water droplets remain on the screen. If the MD4 display is placed in exposed locations where water spray can hit the display, additional splash protection could be used.



#### **NOTICE**

It is recommended to place the display in a vertical position so that water droplets that hit the display roll off the display glass.

#### **Brightness**

The brightness is easily adjusted by pressing the 'menu' touch button and following the prompts to the backlight settings section. The backlight is automatically dimmed at supply voltage <math><14V</math>.

#### **Image persistence**

The IQAN-MD4 TFT LCD, like all other LCD screens, can show image persistence, also known as image sticking, if the same pattern is left on the display for extended periods of time.



#### **NOTICE**

To avoid the possibility of image sticking in applications where the display is rarely powered down, a screen saver that alters the display image could be used.

## Markings/Approvals

The markings/approvals reflect the state of the products at the time of publishing.



### Declaration of Conformity

We: Parker Hannifin Manufacturing Sweden AB  
Mobile Hydraulic Systems Division Europe

Located at: Mölnlycke Fabriker 14  
S-435 35 Mölnlycke, SWEDEN  
Tel. +46 31 750 44 00

Declare that the products identified herein comply with the essential requirements of the following EU directives:

**2014/30/EU**      **EU EMC Directive**  
**2011/65/EU**      **EU RoHS II Directive**

Harmonized standards:

ISO 14982:2009      Agricultural and forestry machines - Electromagnetic compatibility - Test methods and acceptance criteria

ISO 13766-1:2018      Earth-moving and building construction machinery - Electromagnetic compatibility (EMC) of machines with internal electrical power supply - Part 1: General EMC requirements under typical electromagnetic environmental conditions

EN 50581:2012      Technical documentation for the assessment of electrical and electronic products with respect to the restriction of hazardous substances

Trade Name: Electrohydraulic Control Systems

**Products:**      **IQAN-MD4**

Signature of responsible party:

A handwritten signature in black ink, appearing to read "Håkan Jisland".

Printed name of responsible party: Håkan Jisland  
Position of responsible party: Business Unit Manager

Executed on May 12<sup>th</sup> 2021, at Mölnlycke, Sweden



## Declaration of Conformity

We: Parker Hannifin Manufacturing Sweden AB

Located at: Bruksgatan 20  
S-435 35 Mölnlycke, SWEDEN  
Tel. +46 31 750 44 00

Declare that the products identified herein comply with the essential requirements of the following UK regulations:

**S.I. 2016 No. 1091 Electromagnetic Compatibility Regulations 2016**  
**S.I. 2012 No. 3032 The Restriction of the Use of Certain Hazardous Substances in Electrical and Electronic Equipment Regulations 2012**

Designated standards:

ISO 14982:2009 Agricultural and forestry machines - Electromagnetic compatibility - Test methods and acceptance criteria  
ISO 13766-1:2018 Earth-moving and building construction machinery - Electromagnetic compatibility (EMC) of machines with internal electrical power supply - Part 1: General EMC requirements under typical electromagnetic environmental conditions  
EN 50581:2012 Technical documentation for the assessment of electrical and electronic products with respect to the restriction of hazardous substances

Trade Name: Electrohydraulic Control Systems

Products: IQAN-MD4

Signature of responsible party:

A handwritten signature in blue ink, appearing to read "Håkan Jisland".

Printed name of responsible party: Håkan Jisland  
Position of responsible party: Business Unit Manager

Executed on November 3<sup>rd</sup> 2022, at Mölnlycke, Sweden

## 4 Safety

### Internal diagnostics

The module performs a number of self-checks that improve safety. Checks include monitoring of voltage supplies, checksums on memory and a watchdog that monitors software execution. The module is using a real time operating system which supervises software execution.

If a critical error is detected, the module is stopped, with CAN-bus and outputs off.

### CAN-bus interruption

The IQAN modules communicate on a CAN-bus. Both the master module and expansion modules check for any interruptions in CAN-bus communication. If an error occurs the master will use zero or an application defined error value for the module inputs, and the module outputs will be off.

The error will be presented on the master/display module, if there is one, and with a related blink code on the IQAN module status LEDs, see Appendix B.

### Current check

For modules with proportional outputs, when used in current mode a current check is performed. If an error is detected, this will be indicated on the master module, and the output will shut off.

The module can detect open-circuit, short-circuit to +BAT/-BAT or short-circuit to other proportional output and return pins.

### Emergency stop



#### **WARNING**

Risk of injury!

The emergency stop must disconnect the power supply to the module; do not connect the emergency stop as a signal input only.

The emergency stop must be installed so that the risk of reverse feed of the module is avoided, see section "Supply voltage".

## 5 Mounting

### Mounting the module

The IQAN module should be mounted according to the following instructions:

#### Dashboard or panel assembly

When installing in a dash or panel the recommended panel thickness is 1.0 - 3.5 mm. Use M4 screws to attach the supplied steel clips..



Panel mounting the IQAN-MD4

#### Ball or tilt/swivel mount

The option to use ball mounting or tilt swivel mounting for MD4-7 or MD4-5 display position flexibility is made possible by using Parker's steel bracket. Use the provided M4 screws to attach the bracket to the display. The bracket will accept Southco or RAM™ mounts.

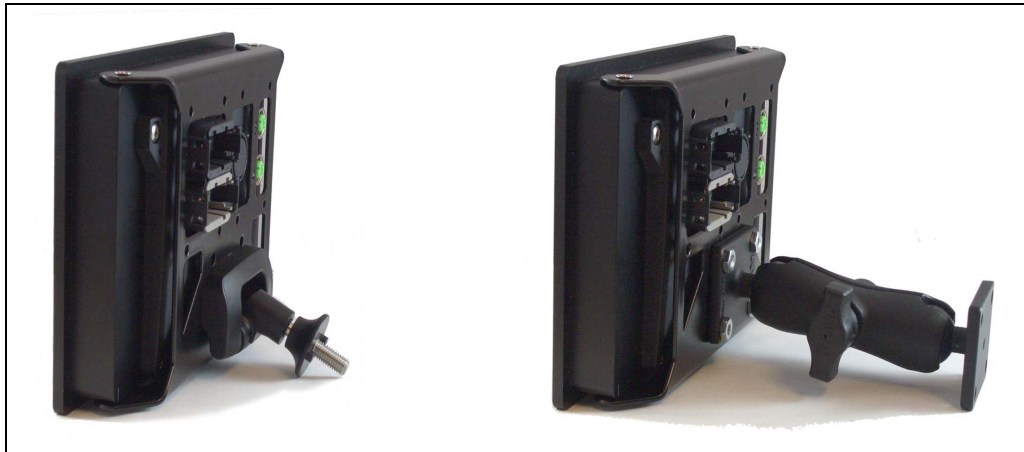

Adjustable mounting the IQAN-MD4

- The part number for the MD4-7 bracket kit is 20077778.
- The part number for the MD4-5 bracket kit is 20077779.

See 'Appendix C' for RAM™ and Southco mounting pattern dimensions.

The IQAN-MD4-10 does not require a bracket. It has a VESA 75 mounting pattern on the back surface which will also accept RAM™ mounts.



## Mounting considerations



### NOTICE

IQAN-MD4 shall be positioned in the machine per the following instructions:

- The unit is designed for outdoor use. Position the unit in desired location and make sure that it is not exposed to mechanical damage.
- The connectors on the reverse side of the unit should be accessible.
- Position the unit so there is no risk that the cabling can be folded, crushed, worn or damaged in any way.
- Leave sufficient room behind the unit to insert connectors. Less than 75 mm clearance will stress the cabling and distort the seals in the connectors. This can cause the environmental specification not to be met.

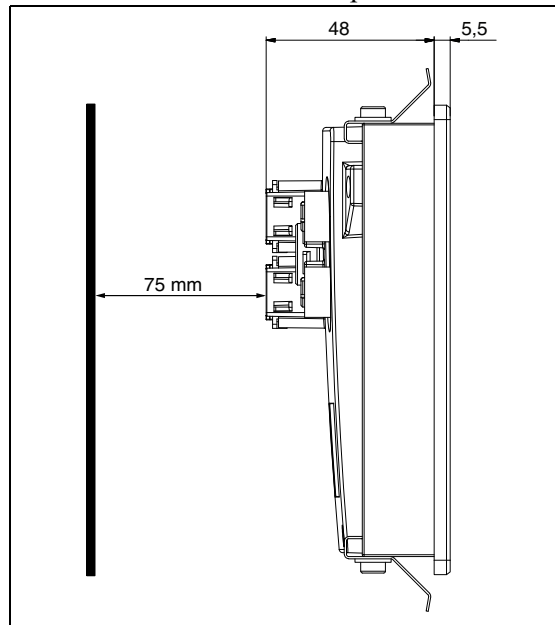

Distance behind the unit.



### NOTICE

- Position the unit so there is no risk to be exposed to external heat, e.g. from the engine or heater.
- The best readability will be achieved by positioning the front face of the unit directly towards the operator.
- Extended periods of exposure to direct sunlight can cause an internal temperature exceeding 90°C which may cause permanent degradation of the LCD display.



### NOTICE

All of the connectors, C1 to C4, must be properly installed in the unit.

- If you leave a connector unplugged, the unit will not be sealed.
- If unused wire positions in a connector are not closed with the recommended plugs, the unit will not be sealed.

## 6 Installation

### Connector C1 and C2

Connector kit	Parker 20073081	C1 (DTM12 key A)
Housing C1	Deutsch no. DTM06-12SA	
Pin type	Deutsch no. 1062-20-0222	
Wedge type	Deutsch no. WM12S	
Sealing plug	Deutsch no. 0413-204-2005	
		C2 (DTM12 key B)
Housing C2	Deutsch no. DTM06-12SB	
Pin type	Deutsch no. 1062-20-0222	
Wedge type	Deutsch no. WM12S	
Sealing plug	Deutsch no. 0413-204-2005	
Recommended cable	0.75-1 mm <sup>2</sup> (18 AWG)	

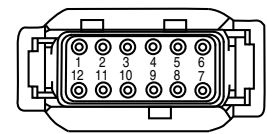
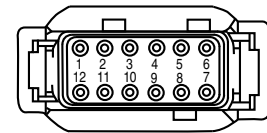

#### NOTICE

No pin may be "double crimped". That means only one wire may be attached to any given pin. Failure to follow this instruction will cause the module to not meet the environmental specification.

Make "Y" connections or splices using weatherproof methods external to the IQAN-MD4 connectors.

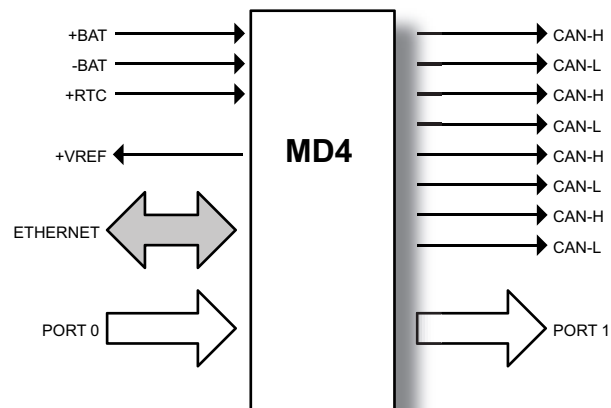

### Connector C1 pin assignments

Pin No.	Symbol	Function
C1:1	-BAT	Power supply
C1:2	CANL-A	CAN low voltage bus line
C1:3	CANL-B	CAN low voltage bus line
C1:4	CANL-C	CAN low voltage bus line
C1:5	CANL-D	CAN low voltage bus line
C1:6	ADDR-L	Low side to address tag. Return (0V)
C1:7	ADDR-H	High side to address tag. Sourcing +5V
C1:8	CANH-D	CAN high voltage bus line
C1:9	CANH-C	CAN high voltage bus line
C1:10	CANH-B	CAN high voltage bus line
C1:11	CANH-A	CAN high voltage bus line
C1:12	+BAT	Power supply

### Connector C2 pin assignments

Pin No.	Function	Alt. Function
C2:1	VIN-A	DIN-I
C2:2	VIN-B	DIN-J
C2:3	DIN-A	DOUT-A
C2:4	DIN-B	DOUT-B
C2:5	DIN-C	DOUT-C
C2:6	DIN-D	DOUT-D
C2:7	DIN-E	
C2:8	DIN-F	
C2:9	DIN-G	+DPCNT-A
C2:10	DIN-H	-DPCNT-A
C2:11	+VREF*	
C2:12	+RTC	

\*Use -BAT on C1 as -VREF. Make the connection as close to the C1 connector as possible to minimise voltage fluctuation.

### Connector C3 and C4

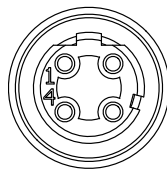
<b>Connector kit</b>	<b>Parker N/A</b>	<b>M12 4pin D-code Industrial Ethernet</b>
Recommended PC cable	20077780	
Sealed panel adapter cable	20077785	

### Connector C3 and C4 pin assignments

Pin No.	Symbol	Function
C3/4:1	TD+	Transmit data +
C3/4:2	RD+	Receive data +
C3/4:3	TD-	Transmit data -
C3/4:4	RD-	Receive data -
C3/4:Shield	Shield	Shield

## Supply voltage

Before any installation of the IQAN system can take place, make sure the ignition lock is turned off and the battery is disconnected.

### Emergency stop

Make sure an *Emergency Stop* disconnecting the power supply, is easily accessible at any time. The figure below shows how to connect the emergency stop.

### Connecting of Supply Voltage

The supply voltage, should be within the operating interval, see Appendix A. Connect the supply voltage to +BAT and -BAT. Protect the module by using a fuse. For recommended fuse level, see Appendix A.

### RTC supply

IQAN master modules have a clock that is used for date/time stamping when logging data. The *real time clock*, +RTC, requires a separate positive power connection.

Connect the supply voltage to +RTC through a 1.5K ohm resistor. The resistor should be as close to the battery as possible for safety.

IQAN expansion modules do not have +RTC.



### WARNING

Risk of injury!

To reduce the risk for uncontrolled supply of an IQAN master module, i.e., a short circuit between the +RTC cable and +BAT, a resistor must be connected between the battery and the +RTC input. This is important as this line is not controlled by an emergency stop.

The resistor should be placed close to the battery, as the 'protected' part is the cable between the resistor and the unit.

This will prevent the +RTC wire from powering up the unit if shorted to +BAT.

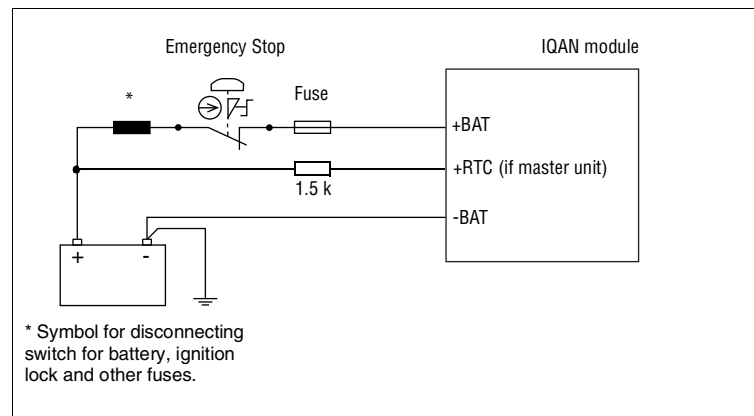

Connecting the emergency stop and voltage supply.



### NOTICE

Do not use the chassis as the negative terminal.

### Polarity reversal

The module is protected against power supply polarity reversal and over-voltage, provided an external fuse is being used.

If this fuse is not used, polarity reversal can damage the unit.

## Addressing

### IQAN-MD4 use of an ID-Tag

In IQANdesign 3.0 and higher software, more than one IQAN master module can be used together in a multi-master system. The master modules are each given a unique address by using an ID-Tag. The value of the ID-Tag identifies the master and will enable a single project application to be loaded into more than one master module over the CAN bus. The functionality needed for each master is loaded based on the ID-tag address.

### Identification of an IQAN-MD4 by address

For normal operation of an IQAN-MD4 in a single master system, the ID-Tag is still used. When no ID-Tag is installed, the MD4 will start in safe mode.

The connection of an ID-Tag between ADDR-H and ADDR-L will assign an address to the IQAN-MD4 master module. The desired functionality based on address is built into the project file using IQANdesign software. For more information, please refer to the IQANdesign user manual. It is the combination of *address* and module *type* that gives each master module a unique identification.

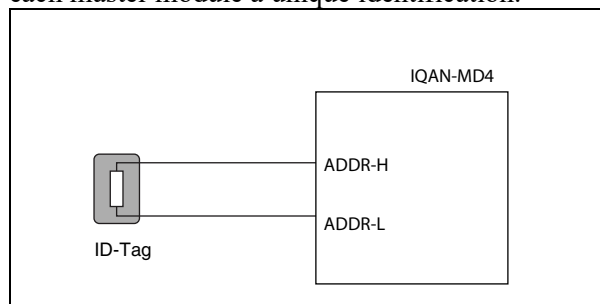

Connecting of ID-Tag.



### NOTICE

When no ID-Tag is installed, the MD4 will start in safe mode.

## Diagnostic interfaces

IQAN software includes many tools for tuning, measuring, accessing logs and otherwise checking the performance or troubleshooting your control system. To use the diagnostic tools with an IQAN master module you may choose between different ways to connect to the unit.

### CAN diagnostics connection

One of the CAN buses of the IQAN master module may be dedicated for diagnostics. Reserving a bus for diagnostics ensures that signals are not interrupted by other bus traffic. A high-speed CAN interface is needed to use this feature. Contact Parker for information about supported CAN interfaces.

A termination resistor is usually required at the CAN interface on the PC. Parker part number 5030082 or 5030182, or an equivalent 120 ohm resistor may be used. A flying lead cable may be connected to the IQAN master to provide a connector interface. The connection from IQAN master module to diagnostic CAN interface can then be made quite easily. It is recommended that the connector be a sealed, automotive type. When not being used this connector should be protected from the environment with a cover or mating blank plug.

The recommended wiring to the IQAN master module connector is shown below.

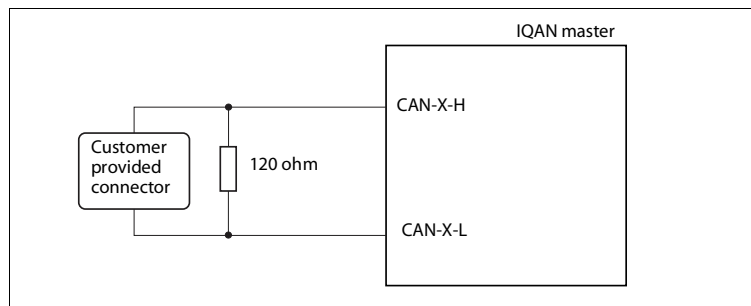

Connecting for CAN communication.

## Ethernet diagnostics communication

The "A" (C3) Ethernet port is used for diagnostic communication or uploading and downloading project files using IQANdesign/IQANrun. On port C3, the IP address is automatically assigned using Dynamic IP (DHCP/link-local auto-IP). As an alternative it is also possible to use IQANdesign to configure the IQAN-MD4 application with a static IP address instead.

It is recommended to use an environmentally sealed panel mounted RJ45 connector for easy access. Parker part number 20077785.

## Video input

The IQAN MD4 master modules are capable of showing video inputs from an external source. For quality images and easy set-up it is recommended to use the IQAN-SV camera. The IQAN-SV is a digital, high resolution IP camera using an Ethernet video link to work together with IQAN-MD4 master displays. All addressing is handled automatically by IQAN software.

When connecting a video source to the system it is the ethernet port "B" (C4) that is used.

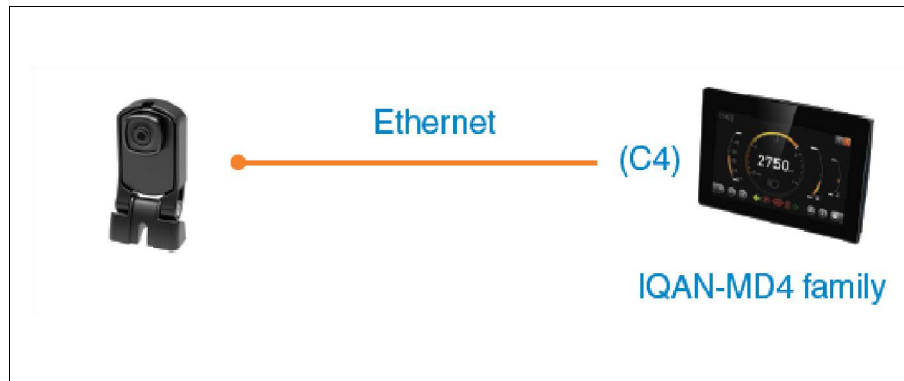

IQAN-SV camera in a system



### NOTICE

IQAN-MD4 and the vision system is expandable to 2 camera inputs by also using port C3 (IQAN software 4.02 and newer).

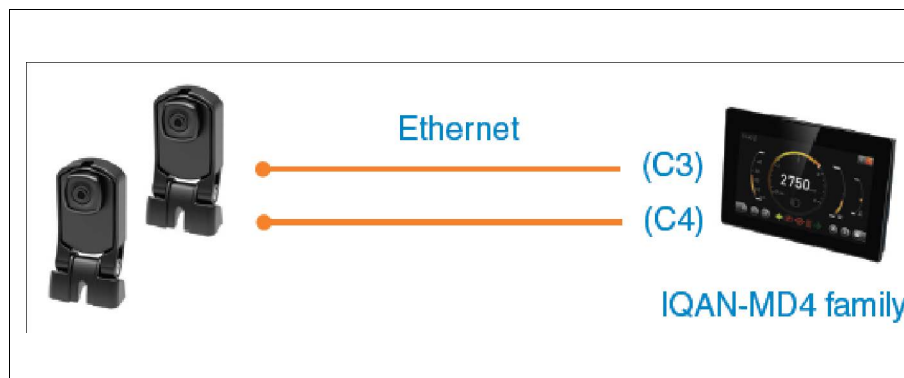

2 x IQAN-SV camera in a system

IQAN-MD4 and the vision system is expandable to a number of cameras by use of an Ethernet switch.



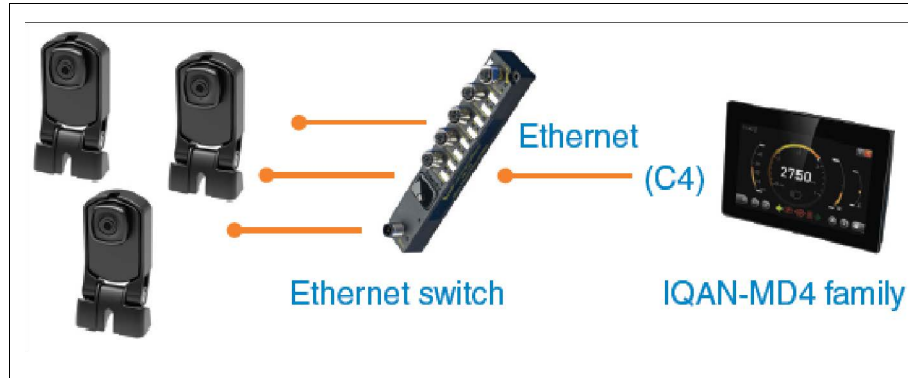

Multiple IQAN-SV cameras in a system

The C4 port is dedicated for the in-vehicle network (i.e video input, master-to-master communication). On port C4 when using generic cameras, the MD4 can use DHCP and assign a dynamic address (IQAN software 4.02 and newer). If you use static IP addresses, the generic camera must have a valid and unique IP address set beforehand in order to be used, see IQANdesign manual for valid IP address range.

For information on how to set the generic camera IP address see the camera manufacturer's instruction book.



#### NOTICE

The IQAN-MD4 use motion JPEG (MJPEG) as video format when communicating with cameras. The type of signal supported is RTSP (real time streaming protocol). A single camera may be connected directly to the unit. The camera must be powered, there is no POE (power over ethernet) available.

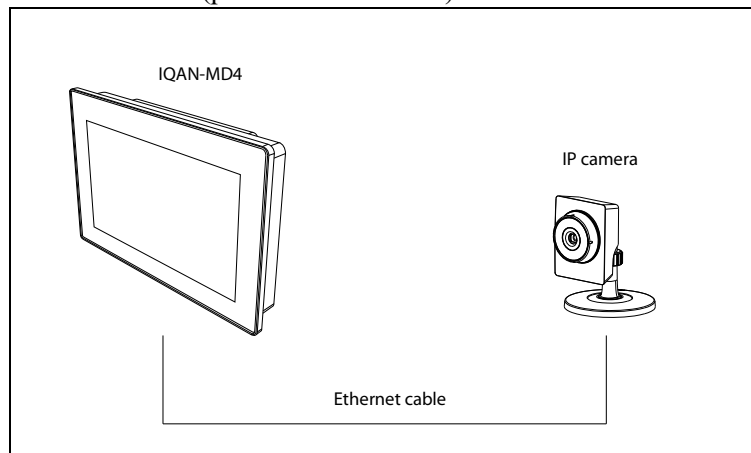

Connecting a camera to the MD4 display.

Using an ethernet switch it is possible to have multiple cameras connected to one MD4 or to have one *static IP address* camera connected to multiple MD4 displays.

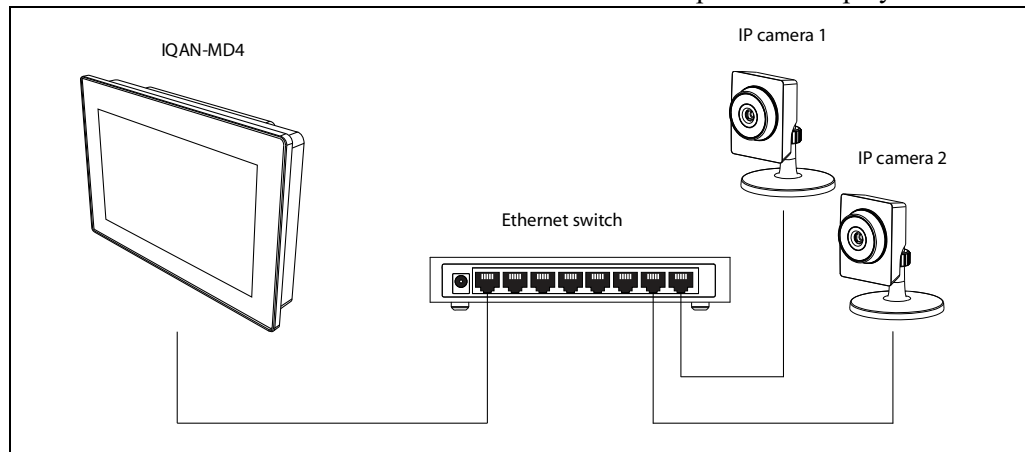

Connecting multiple cameras to one MD4.



#### **NOTICE**

When cameras are assigned an IP address using DHCP, their video stream can only be shown on the MD4 that assigned the address to the camera. The other will have a blank video image. A video stream can only be shared with multiple MD4 units from a generic, static IP address camera.

#### **Analog Cameras**

It is also possible to connect an analog camera by routing the video feed through a video encoder/server with ethernet connection.

## Reference voltage, $V_{REF}$

The IQAN module is internally equipped with a voltage regulator to generate the reference voltage  $V_{REF}$ . The standard reference voltage will feed different kinds of sensors and potentiometers.

On the IQAN-MD4 there is no  $-V_{REF}$  pin, instead the  $-BAT$  is used as  $-V_{REF}$ . To get the best result, connect as close to the connector as possible to minimise voltage fluctuations. In connection examples that follow,  $-V_{REF}$  will refer to the  $-BAT$  pin.

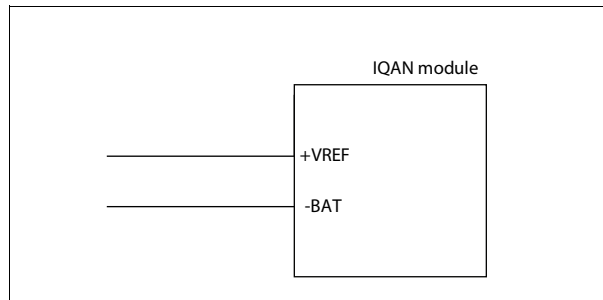

$V_{REF}$  positions.



### NOTICE

Maximum load for the  $V_{REF}$  is different according to 12/24 Vdc power supply, see "Appendix A".

## Voltage inputs

### Connecting sensors to the voltage inputs

The sensor signal range must be 0-5 Vdc. To detect signal errors such as short circuits or interruptions the active signal range be within 0.5-4.5 Vdc.

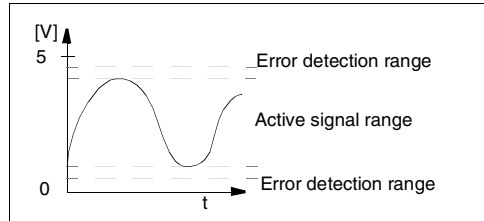

Active signal range.

The current consumption related to the voltage input is negligible.

The positive terminal of the sensor is connected to the +VREF position and the corresponding negative terminal to the -VREF position. The sensor signal is connected to appropriate VIN position.

#### EXAMPLE

Connect the positive and negative terminals of the position sensor to +VREF, and -VREF, respectively. Then connect the sensor signal to VIN-X.

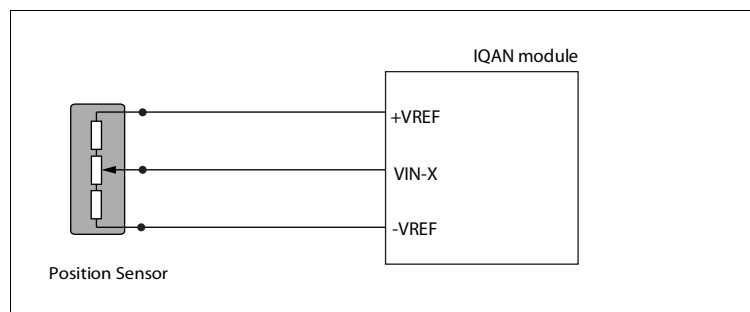

Connecting VREF and sensor signal VIN-X.



#### NOTICE

The negative terminal of the sensor must not be connected to the chassis.  
Maximum load for VREF position: see Appendix A.

#### Connecting other 3 wire sensors

The same type of connection shown for potentiometers is used for other 3 wire sensors supplied with power from the regulated 5VDC supply, VREF. This includes active temperature sensor IQAN-ST, pressure sensor IQAN-SP and Hall-effect levers IQAN-LST or IQAN-LSL.

### Connecting a 2-wire temperature sensor to voltage in

When you connect a PTC (positive temperature coefficient) temperature sensor you may need to use a pull up resistor on the input signal. Please check the technical data for your specific temperature sensor.

#### EXAMPLE

Connect the negative terminal of the temperature sensor to -VREF, and the signal to VIN-X. The pull up resistor will be connected between VIN-X, and +VREF.

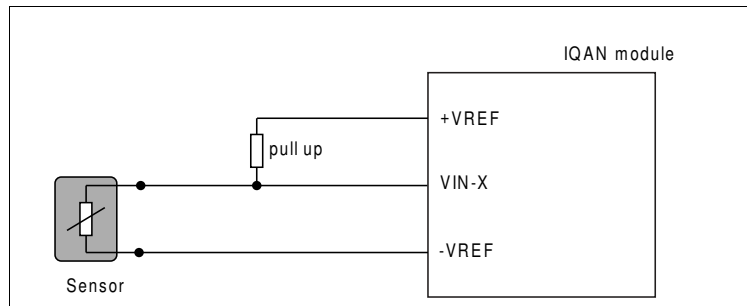

Connecting -VREF and temperature sensor signal VIN-X.

The pull up resistor value for a  $R_{25}=2000\Omega$ , PTC sensor is 4,7 K $\Omega$ .

### Connecting switches to the voltage inputs using VREF

Switches could be connected to the voltage inputs, to create a digital on/off signal. The switches should be connected to +VREF and VIN/DIN respectively for 5V signal. The current consumption for the input is negligible.

#### EXAMPLE

Connect the positive and negative terminals of the switch to +VREF, and VIN-X, respectively.

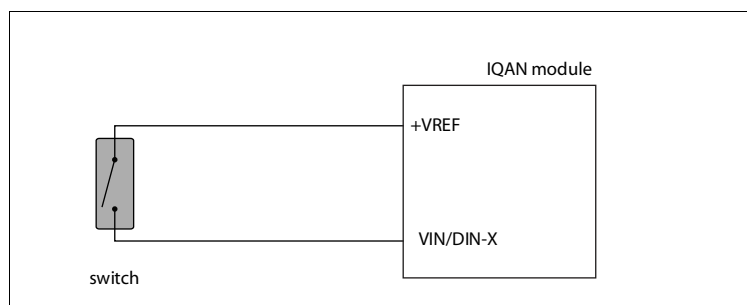

Connecting a switch to VIN-X and VREF.



#### NOTICE

Maximum load for VREF position, see "Appendix A".

---

### Connecting switches to the voltage inputs using +BAT

It is recommended to connect system voltage +BAT to the input through a switch in order to reserve 5Vdc VREF for sensors and potentiometers.

---

#### EXAMPLE

Connect the positive and negative terminals of the switch to supply or the unit's +BAT, and DIN-X, respectively.

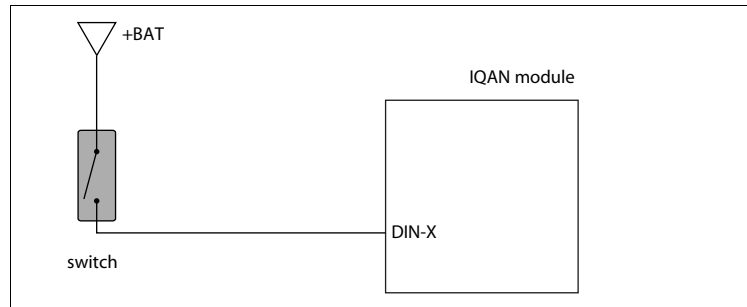

Connecting a switch to DIN-X and +BAT.

---

## Directional pulse count input

### Connecting a directional pulse count channel (DPCNT)

The DPCNT is a physical analog input. The directional pulse count input channel is used to count pulses. It is bi-directional, which means it can add and subtract pulses.

The DPCNT is primarily designed for input from an encoder wheel. For maximum frequency, see Appendix A.

### Simple directional pulse count sensor

The positive terminal of the directional pulse count sensor is connected to the +VREF and the negative terminal to the -VREF respectively. The sensor signals are connected to the DPCNT+ and DPCNT- positions..

### EXAMPLE

Connect the positive and negative terminals of the frequency sensor to +VREF and -VREF, respectively. Then connect the sensor signals to DPCNT+ and DPCNT-.

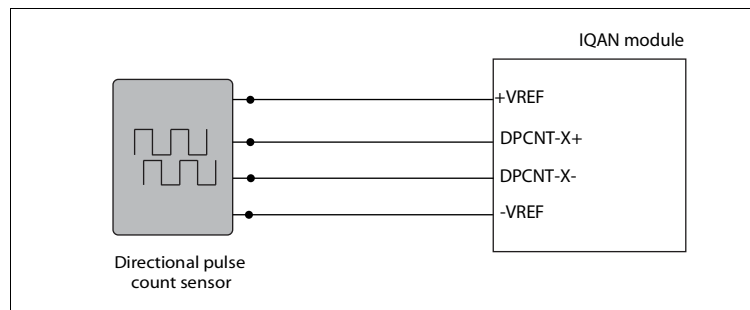

Connecting of directional frequency sensor to DFIN+ and DFIN-.



### NOTICE

The negative terminal of the sensor must not be connected to the chassis. Maximum load for VREF position, see Appendix A.

---

## Low-side digital outputs

The low-side digital outputs are designed to drive small loads, e.g. lamps and buzzers. Low-side digital outputs work by grounding a signal through the module. See Appendix A for maximum loads per output.

---

### EXAMPLE

Connect the lamp to the low-side digital outputs using a DOUT(LS)-X position, and the +BAT, as supply.

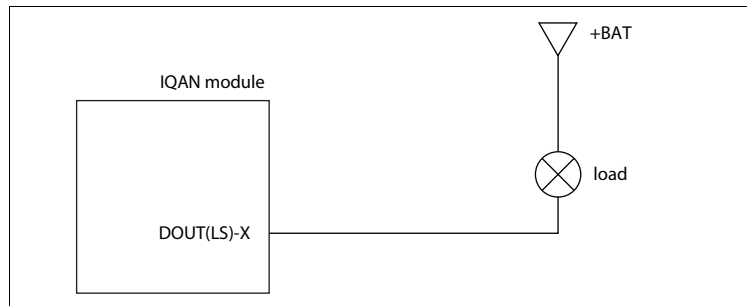

Connecting a switch to DOUT(LS)-X and +BAT.

---



## 7 Start-up

### Start-up procedures

This chapter contains instructions for action to be taken in connection with the initial start.



#### **WARNING**

Risk of injury!

If the control system is not fitted properly, the machine could move uncontrollably. The machine's engine shall not be started before the control system is completely fitted and its signals are verified.

### Starting the control system

#### **Start the control system as follows:**

- Prior to start, all modules and cables are to be fitted correctly.
- Check fuses, i.e. make sure that the supply voltage to the modules is equipped with the correct fuse.
- Make sure that connections for supply voltage and return lines are correct in the cable's conductor joint.
- Make sure an emergency stop is installed.  
The emergency stop should disconnect the supply voltage to all modules. Alternatively, the emergency stop may also shut off the diesel engine or a dump valve, and with that, depressurize the hydraulic system.

### Prepare for system start



#### **WARNING**

Make sure no one is in dangerous proximity to the vehicle to avoid injuries when it starts.

#### **Prepare for the initial system start as follows:**

- The engine for the hydraulic system's pump shall be in off position.
- Make sure that all connectors are properly connected.
- Turn on the control system.
- Make sure that voltage is being supplied to all modules; the power/status diode shall be illuminated on all modules. Also, make sure that the master is in contact with all modules by reading the master's display.
- Make sure the emergency stop is functioning properly.

### Start the system

#### **Start the system as follows:**

- Start the engine for the hydraulic system's pump, assuming that the above mentioned inspections have been carried out and shown correct values.

Calibrate and adjust input and output signals according to the instructions related to the master menu system and check each and every output function carefully.

## Appendix A

### IQAN-MD4 Technical Overview

#### Absolute Maximum Ratings<sup>a</sup>

Ambient temperature	-30 to 70 °C
Storage temperature	-40 to 85 °C
Voltage supply on +BAT	6.5 to 36 V
Reverse polarity protection on +BAT	36 V with external 20A fuse (recommended fuse 3A to 5A)
Voltage on any pin with respect to -BAT	36 V

a. The "Absolute Maximum Ratings" table lists the maximum limits to which the device can be subjected without damage. **This doesn't imply that the device will function at these extreme conditions**, only that, when these conditions are removed and the device operated within the "Recommended Operating Conditions", it will still be functional and its useful life won't have been shortened.

#### Environmental ratings

<b>Climate environment</b> Enclosure, water & dust protection Salt mist Damp heat cyclic Damp heat steady state Heat, operation Cold Change of temperature	IEC 60529:2001, IP65; (front and back) IEC 60068-2-52:1996 Kb, 72 h IEC 60068-2-30:2005 Db, +55°C, 95% RH, 6 cycles IEC 60068-2-78:2001 Cab, +40°C, 93% RH, 21 days IEC 60068-2-2:2007 Bb, +70°C, 72 hours IEC 60068-2-1:1993 Ab, -30°C, 16 hours IEC 60068-2-14:1984 Nb, -30°C to +55°C, 10 x 8 hours
<b>Mechanical environment</b> Random vibration, MD4-7 Random vibration, MD4-5 Random vibration, MD4-10 Bump	IEC 60068-2-64: 2008 Fh, 15 - 1000 Hz, 7.1 Grms, 3 x 10 h IEC 60068-2-64: 2008 Fh, 15 - 2000 Hz, 4.0 Grms, 3 x 10 h IEC 60068-2-64: 2008 Fh, 15 - 2000 Hz, 4.0 Grms, 3 x 10 h IEC 60068-2-27:2008 Ea, 40 g, 6 ms, 1000 * 6 dir
<b>EMC</b> Radiated emission Conducted emission, MD4-7 Conducted emission, MD4-5 Conducted emission, MD4-10 Conducted emission, transients Conducted susceptibility Radiated susceptibility  Conducted transients susceptibility  ESD, Operation ESD, Handling	ISO 13766-1:2018/ISO 14982:2009 EN 55025:2008, 0.15-108 MHz, Class 2 EN 55025:2008, 0.15-108 MHz, Class 2 EN 55025:2008, 0.15-108 MHz, Class 1 ISO 7637-2:2004, 12/24 V, Level 2 ISO 11452-4:2011, 1 - 200 MHz, 1 kHz, 80% AM, 150 mA ISO 11452-2:2004, 20-2000 MHz, 1kHz, 80% AM, 60-100 V/m ISO 11452-2:2004, 800-2000 MHz, PM 577 µs / 4.6 ms, 60 V/m ISO 7637-2:2004, Pulse 1, 2a, 2b, 3a, 3b, Level 3 ISO 16750-2:2012, Starting profile:level 4, Load dump:level 3 ISO 7637-3:2007, Level 3 ISO 10605:2008, 8 kV (contact), 25 kV (air) ISO 10605:2008, 8 kV (contact)

#### Markings / Approvals

CE	2014/30/EU, EMC directive
	2011/65/EU, ROHS 2 directive
UKCA	EMC regulations 2016
	ROHS regulations 2012
E-mark	
MD4-5-T1E2-M19	ECE Regulation No. 10.05
	Approval number E5 10 R - 0401
MD4-7	ECE Regulation No. 10.05
	Approval number E5 10 R - 0408

## Markings / Approvals

MD4-10	ECE Regulation No. 10.05
	Approval number E5 10 R - 0407
MD4-5-T0E1/T1E2	No E-mark

## System

$T_A = -30$  to  $+70$  °C, unless otherwise specified

Weight MD4-7 MD4-5 MD4-10	930g 670g 1500g
Ambient temperature, $T_{ROC}$ MD4-5, MD4-7, MD4-10 MD4-5 M19	-30 to 70 °C -20 to 70 °C
Voltage supply on +BAT, $V_{BAT}$ LCD backlight	9 to 32 V off below 9 V
Current supply $V_{BAT} = 14V$ $V_{BAT} = 28V$	600 mA 300 mA
Current supply RTC $V_{BAT} = 14V$ $V_{BAT} = 28V$ RTC backup time	1.7 mA 3.7 mA 14 days, $V_{BAT}=0$ , $V_{RTC}=0$ , $T_A=+25$ °C (7 days $T_A = -30$ to $+70$ °C)
Start-up time Embedded functions HMI running	1.7 s (typical) 4.3 s (typical)
System cycle time, $T_{SC}$	10 ms to 100 ms
Embedded Flash memory	2 GB
Embedded RAM memory	256 MB
Data log memory	64 MB

## LCD - MD4-7 (7 inch)

Resolution	800 x 480 dots
Number of Colors	262 K
Active area	152 x 91 mm
Brightness	800 cd/m <sup>2</sup> (reduced to 50% if $V_{BAT}<14$ V)
Viewing angle	85 degree all directions
Contrast Ratio	600
Maximum allowed dot-defect (1 dot / 2 adj. dot)	Bright dot 4/1, Dark dot 5/2
Touch sensor	PCAP

## LCD - MD4-5 (5.7 inch)

Resolution	640 x 480 dots
Number of Colors	262 K
Active area	115 x 86 mm
Brightness	800 cd/m <sup>2</sup> (reduced to 50% if $V_{BAT}<14$ V)
Viewing angle	80 degree all directions

**LCD - MD4-5 (5.7 inch)**

Contrast Ratio	400
Maximum allowed dot-defect (1 dot / 2 adj. dot)	Bright dot 4/1, Dark dot 5/2
Touch sensor	PCAP (depends on variant)

**LCD - MD4-5 M19 (5.7 inch)**

Resolution	640 x 480 dots
Number of Colors	262 K
Active area	115 x 86 mm
Brightness	570 cd/m <sup>2</sup> (reduced to 50% if V <sub>BAT</sub> <14 V)
Viewing angle	60/70/40/70 degree (Seen as landscape 12/3/6/9 o'clock)
Contrast Ratio	300
Maximum allowed dot-defect (1 dot / 2 adj. dot)	Bright dot 4/1, Dark dot 5/2
Touch sensor	PCAP

**LCD - MD4-10 (10.1 inch)**

Resolution	800 x 600 dots
Number of Colors	262 K
Active area	211 x 158 mm
Brightness	1000 cd/m <sup>2</sup> (reduced to 50% if V <sub>BAT</sub> <14 V)
Viewing angle	80 degree all directions
Contrast Ratio	400
Maximum allowed dot-defect (1 dot / 2 adj. dot)	Bright dot 4/2, Dark dot 5/2
Touch sensor	PCAP

**Sensor supply - VREF**

Number of VREF	1
Output voltage	5 V ±150 mV, -30 to 70 °C
Output voltage temperature drift	0.50 mV/°C
Maximum load current	50 mA
Protection	over load, SCB, SCG
Diagnostics	over/under voltage
Under/over voltage threshold	±150 mV from nominal value

**Signal input - VIN**

Number of VIN	2 (configuration may reduce number)
VIN full scale	5000 mV ±100 mV
VIN resolution	12 bits = 1.22 mV
Input impedance	36 kohm in parallel with 10 nF
Accuracy	± (1% + 25mV)

**Signal input - VIN**

Sample rate	Same as system cycle time $T_{SC}$
Maximum continuous voltage	32V
Protection	SCB, SCG
Diagnostics	defined in application

**Signal input - DIN**

Number of DIN	10 (configuration may reduce number)
Logic levels low high hysteresis	<0.5 V >3 V >150 mV
Input impedance	6.8 kohm
Sample rate	Same as system cycle time $T_{SC}$
Maximum continuous voltage	32 V
Diagnostics	defined in application

**Signal input - DPCNT**

Number of DPCNT	1 (configuration may reduce number)
Frequency range	0 to 500 Hz, 50/50 signal
Minimum pulse width	1 ms
Logic levels low high hysteresis	<0.5 V >3 V >150 mV
Input impedance	6.8 kohm
Maximum continuous voltage	32 V
Diagnostics	defined in application

**Power driver - DOUT**

Number of DOUT low-side	4 (configuration may reduce number)
Maximum load Single channel All channels	300 mA 850 mA
Minimum load	2 mA
Leakage current in OFF state	<200 $\mu$ A
Protection	over load, SCB, SCG
Diagnostics Operational ON Operational OFF	over load open load

**CAN**

Number of CAN buses MD4-5-T0E1 All other variants	2 4
CAN specification	2.0A and 2.0B
CAN bus speed	125 kbit to 500 kbit
Protection	SCB, SCG

---

## Ethernet

Number of Ethernet ports MD4-5-T0E1 All other variants	(PC diagnostic, only port A, NOT port B) 1 2
Network interface	100 Base-TX, 10 Base-T, Auto-MDIX (auto crossover)
Network protocol	TCP/IP, UDP, DHCP
Communication rates	10/100 Mbps, auto-negotiated
Streaming video Video format Video resolution	Motion JPEG (MJPEG) limited by screen resolution

## Appendix B

### Error messages and actions

If a fault is detected, a message will be presented on the display.



#### WARNING

An error message could indicate that a hazardous situation exists. If precautions are not taken, this could result in death, serious injury or major property damage.

### Failure Modes

The following tables contain information about the different possible failures that could occur for each module subsystem. In most cases when an error is detected, a message will be presented on the master display. In some cases, the master will turn off or at least shut down the outputs, to increase safety.

#### Failure modes for CAN interface

Failure mode		Effect
1	CAN-H to -BAT	No CAN communication. All output turned off.
2	CAN-L to -BAT	No CAN communication. All output turned off.
3	CAN-H to +BAT	No CAN communication. All output turned off.
4	CAN-L to +BAT	No CAN communication. All output turned off.
5	CAN-L open circuit	No CAN communication. All output turned off.
6	CAN-H open circuit	No CAN communication. All output turned off.
7	CAN-L to CAN-H	No CAN communication. All output turned off.
8	CAN-termination failure, termination on	No effect
9	CAN-termination failure, termination off	Dependent on CAN size and number of CAN nodes.

### Failure modes for VREF

Failure mode		Effect
1	+VREF Open	VIN out of range, will create a VIN error => VIN=Predefined error value.
2	-VREF Open	VIN out of range, will create a VIN error => VIN=Predefined error value.
3	+VREF Short-circuit to -VREF	VREF error => VIN out of range, will create a VIN error => VIN=Predefined error value.
4	+VREF Short-circuited to +BAT	VREF error => VIN out of range, will create a VIN error => VIN=Predefined error value.
5	+VREF Short-circuited to -BAT	VREF error => VIN out of range, will create a VIN error => VIN=Predefined error value.
6	-VREF Short-circuited to +BAT	External fuse (if <7.5A) on +BAT blows.
7	-VREF Short-circuited to -BAT	Not detected.

### Failure modes for VIN

Failure mode		Effect
1	VIN Open	VIN out of range, will create a VIN error => VIN=Predefined error value <sup>1</sup>
2	VIN Short-circuited to +BAT	VIN out of range, will create a VIN error => VIN=Predefined error value <sup>1</sup>
3	VIN Short-circuited to -BAT	VIN out of range, will create a VIN error => VIN=Predefined error value <sup>1</sup>

1. Measure is controlled by CAN master and application as a result from the CAN error message. Turning outputs off is controlled by CAN master unit and therefore delayed maximum 2 bus cycles.

### Failure modes for DIN

Failure mode		Effect
1	DIN Open	No effect on module, not detected
2	DIN Short-circuited to +BAT	No effect on module, not detected
3	DIN Short-circuited to -BAT	No effect on module, not detected



## Appendix C

### Dimensioning of the IQAN-MD4-7

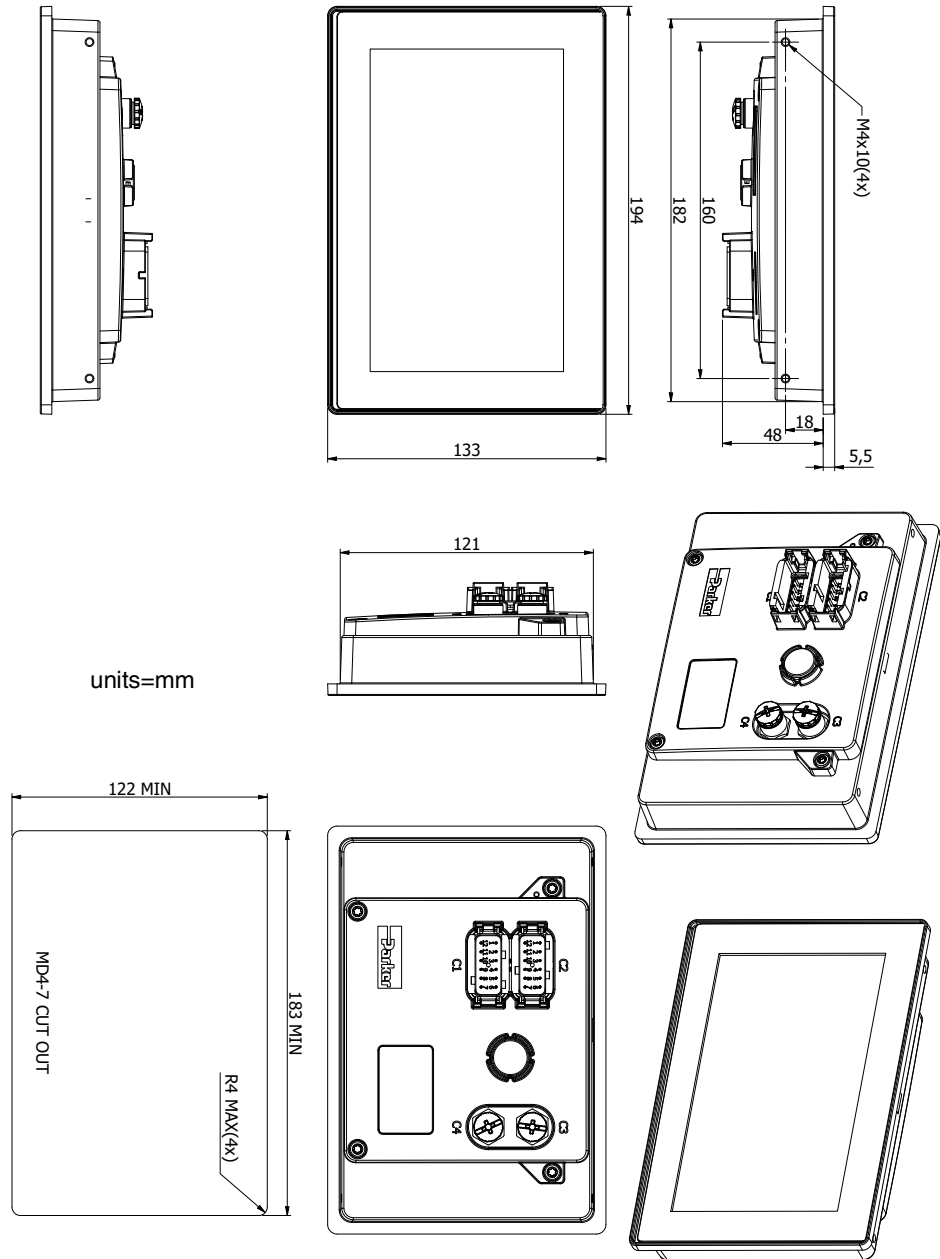

## Dimensioning of the IQAN-MD4-5

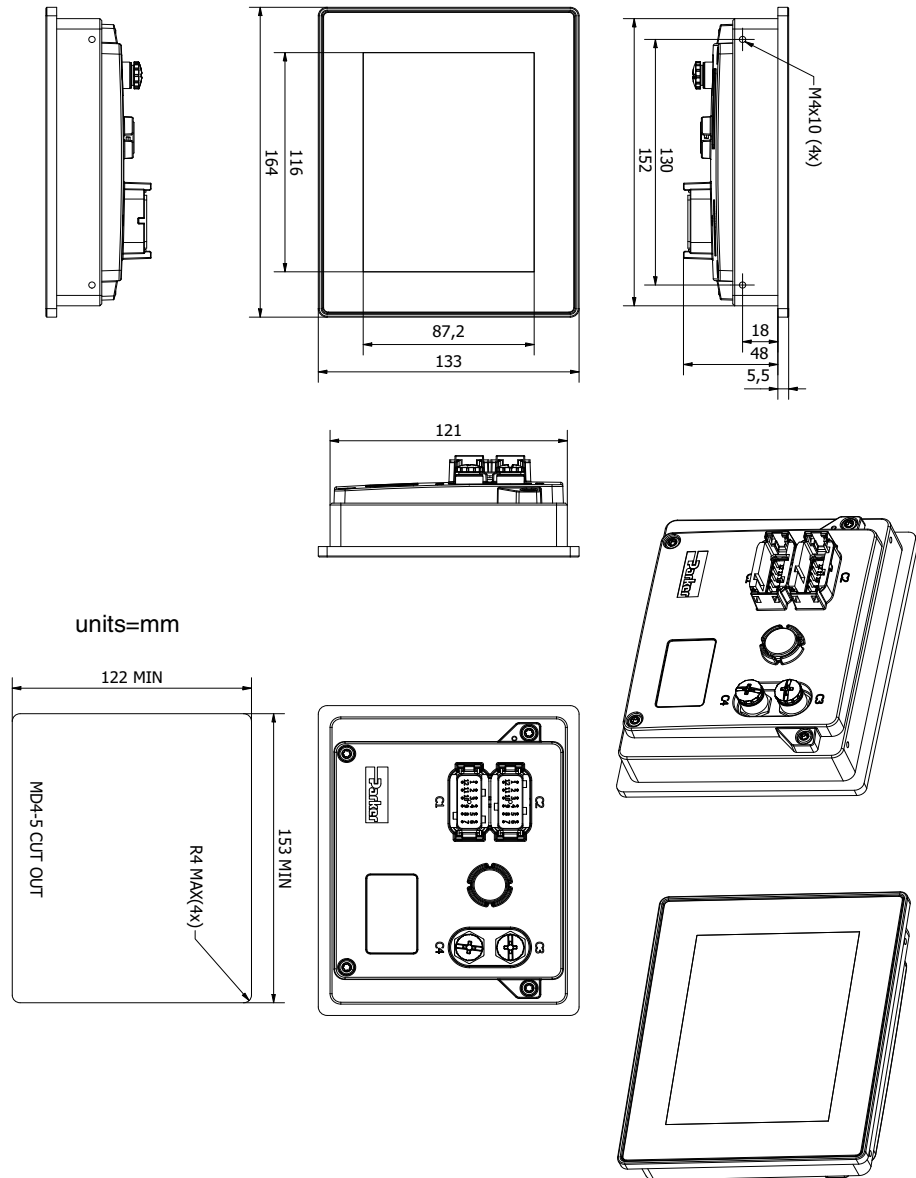

## Dimensioning of the IQAN-MD4-10

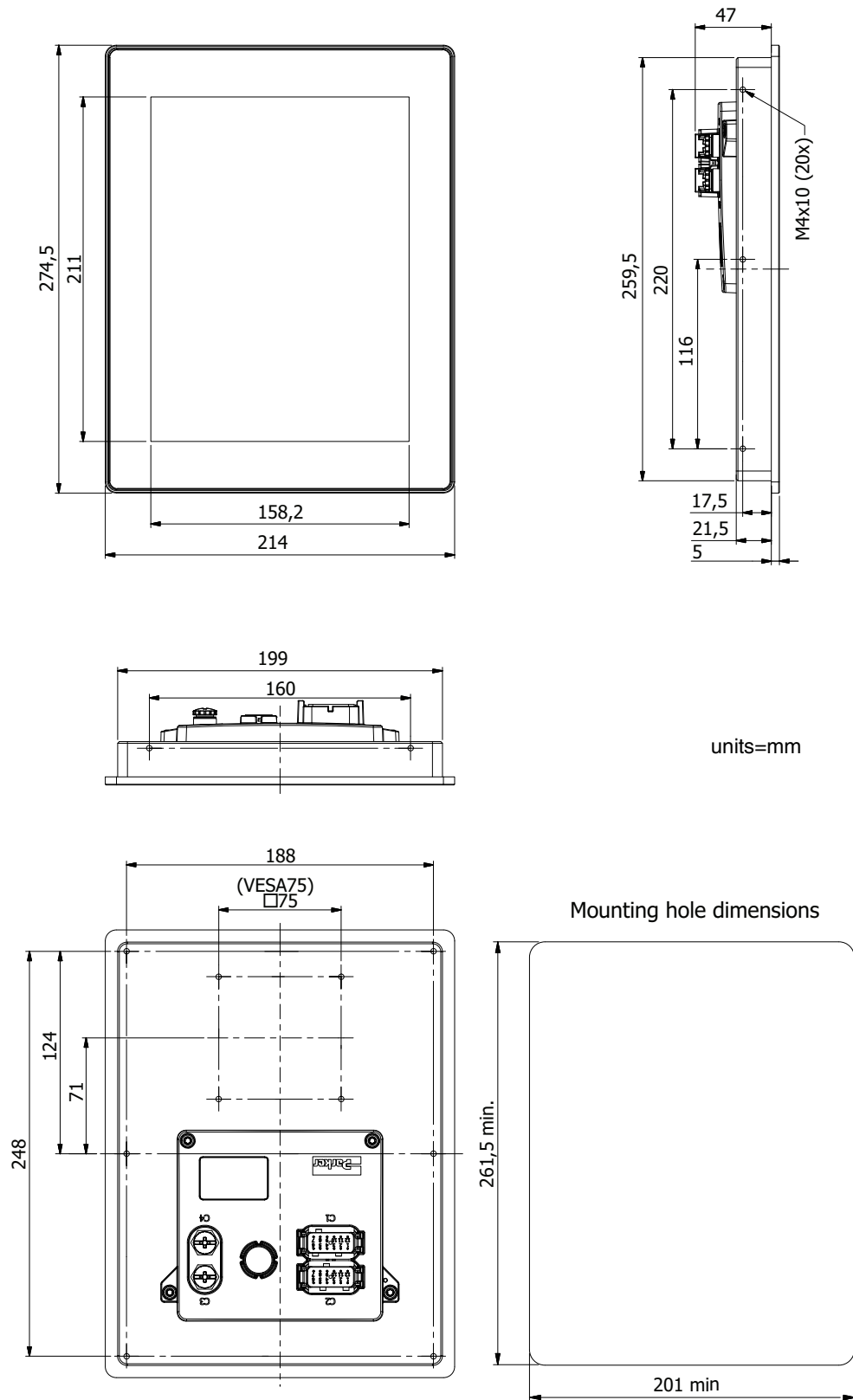

### Dimensioning of the IQAN-MD4 bracket

Example is MD4-7 bracket

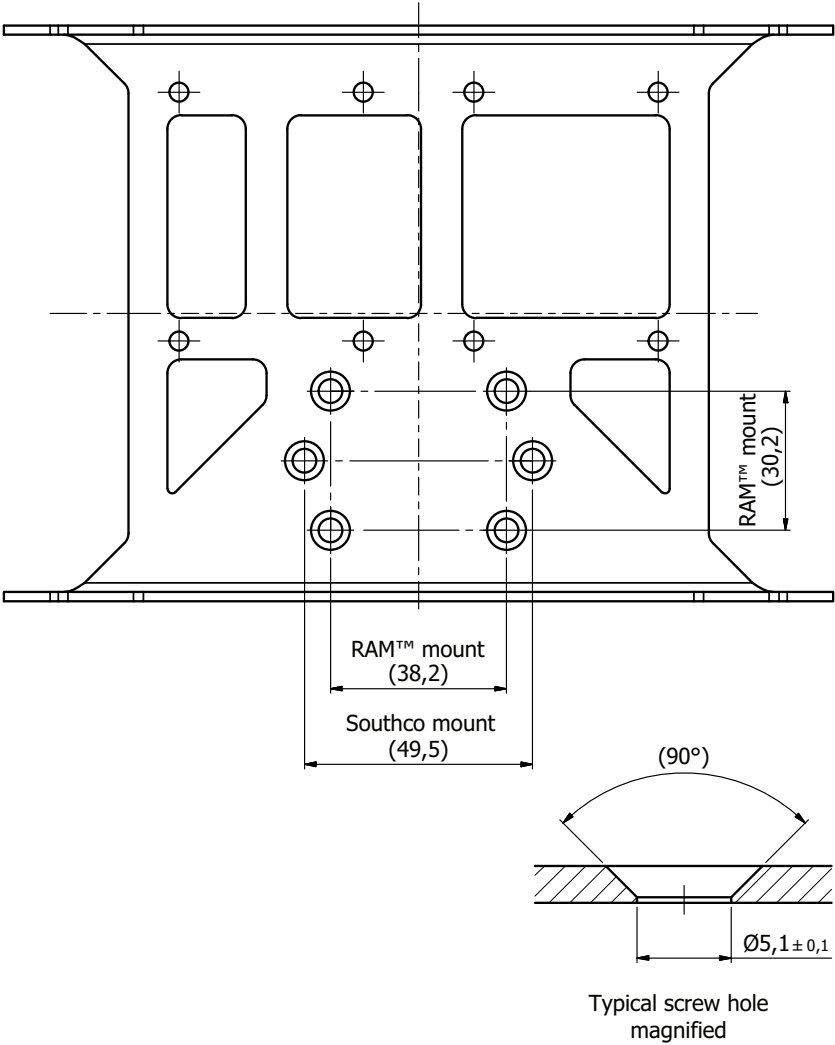

units=mm

For latest information visit our website [www.iqan.com](http://www.iqan.com)

Information in this instructionbook is subject to change without notice

**Parker Hannifin**  
Mobile Systems Division  
SE-435 35 Mölnlycke  
Sweden  
Tel +46 31 750 44 00  
Fax +46 31 750 44 21  
[www.parker.com](http://www.parker.com)

**Parker Hannifin**  
Electronic Controls Division  
1651 N. Main Street  
Morton, IL 61550  
USA  
Tel +1 309 263 7788  
Fax +1 309 266 6674

Publ no MSG17-8408-IB/UK  
Edition 2022-11-04

